



Mechanical procurement Dept
Material Guide



Water distribution system

AHC able to provide Bolted Steel water storage according to AWWA D103. the tank is hot deep galvanized and complete with manway, vent, inlet and outlets openings as flanged type



Also we able to provide GRP Tank with capacity 250 M3, and provide technical support for installation

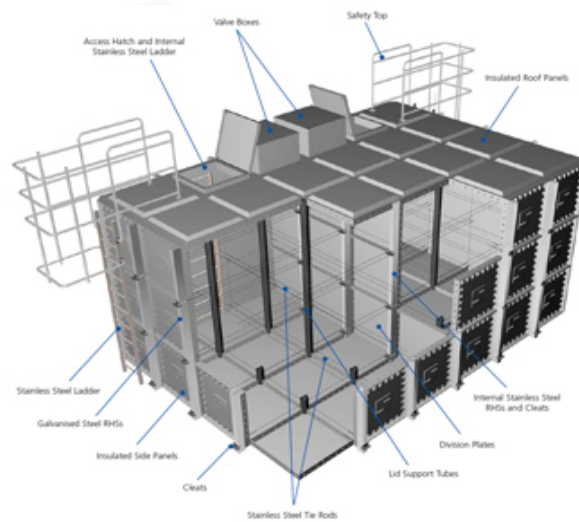



Booster Pump Station

AHC can provide Booster Pump Stations meet the Specification as factory-packaged assembly, complete with valves, strainers, check valves, pressure switch and control panel



AHC can Provide design drawings for the pumping station skid floor, pumps, valves, electrical, control systems, pressure control system and appurtenances. Submittals shall also include drawings of proposed equipment giving general dimensions sufficient to determine how the equipment is to be supported and how it will fit within the space available.

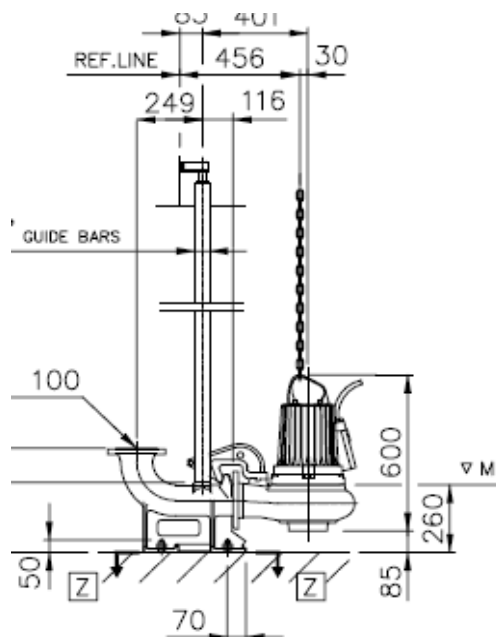

Submersible pump



Water distribution system

AHC able to provide PIPES conforming to ASTM D 1784, Class 12454B, ASTM D 1785, DIN 8061, DIN 8062, or DIN 8063.



PCV FITTINGS AS PER ASTM D 2467 or DIN 8063

AHC can provide Valve conform to AWWA C500, DIN 3352, or BS 5163.

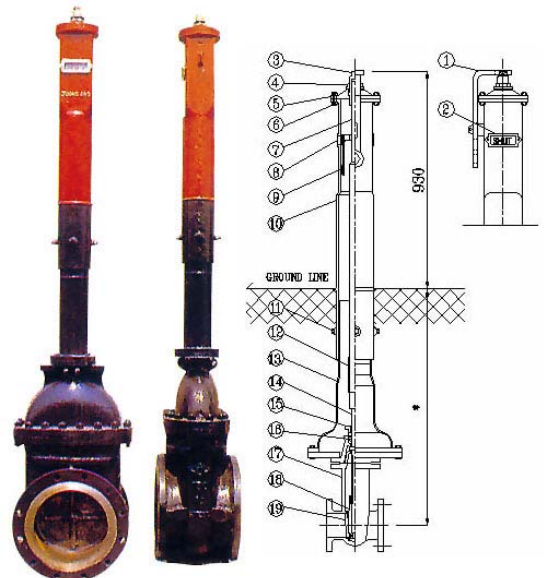

Gate Valve Mechanical joints Used as buried type in site utilities complete with valve box and extension required with all accessories



Sewer distribution system

AHC able to provide SEWER PIPES conforming to ASTM D 3034, DIN 8061 and DIN 8062 (6 bars),





HVAC Package units system

AHC can provide all HVAC package units system (conditioning unit , condensing unit and Air handling units complete with control system required for operation)



Conditioning unit



condensing unit

AHC able to provide the technical support for the selection of units according to drawings schedule



AIR HANDLING UNIT



The new YORK® Latitude™ air-cooled chillers offer the lowest total cost of ownership, best-in-class energy efficiency and quietest operation of any air-cooled chiller. Units are now available up to 515 TR – the largest tonnage in a single-piece unit.

CHILLER SYSTEM



DUCT WORK ACCESSORIES

AHC can provide Duct Accessories (Dampers , Fire Dampers , Splitters and Manual Balancing Dampers , Air Deflectors and Branch Connections , Plenum and Casings , Diffusers, Registers, Grilles , Louvers)



Louvers



Dampers

AHC can provide also all accessories of compressed Air system (Air Dryer, Pressure Regulators, Air Filters and Lubricators)

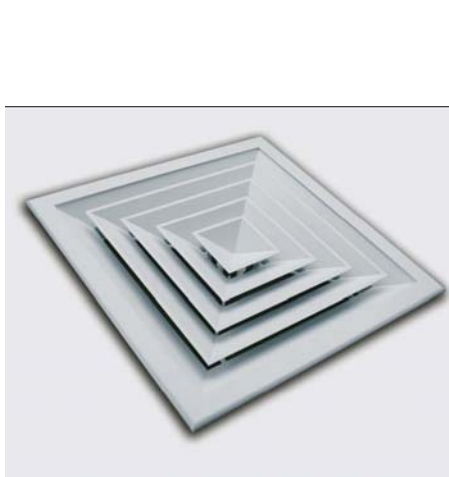

Diffusers



Plenum and Casings



EXHUAUST FANS

AHC can provide all exhaust fans types according to UL 705 or Equivalent DIN, I.E.C., BS, or EN standards Complete with back draft damper and disconnect switch



Wall mounted exhaust fan



Roof mounted exhaust fan

AHC able to provide the technical support for the selection of units according to drawings schedule

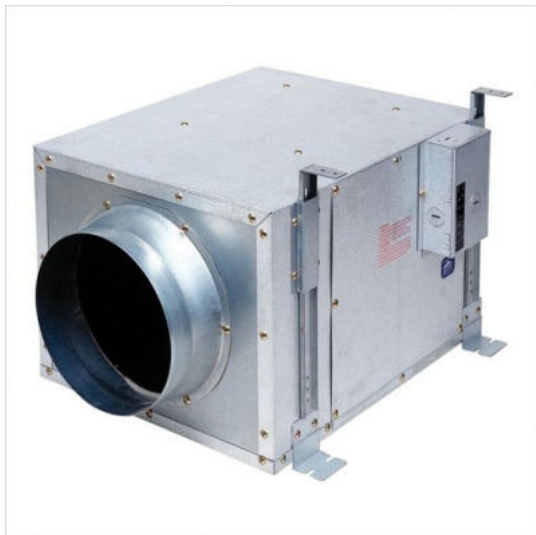

In line duct supply fan



Duct heater wall mounted type



Fuel storage system

AHC specialist in fuel storage tank as per ASME standard and comply with UL 142



Also we are able to supply all tank accessories



1- emergency vent



2-Tank atmospheric vent



2- 3-tank overfill alarm system



4- tank overfill protection valve



Fuel loading and transfer Pumps

AHC can provide all types of fuel pump system especially for loading pump and transfer pump according to American specifications



Smart Loading Pump

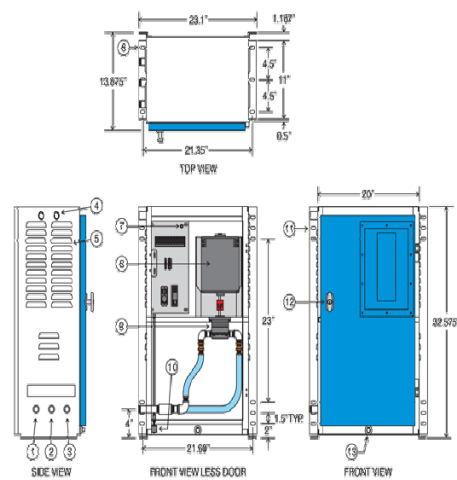

Smart Transfer pump



Fuel storage system

AHC specialist in fuel equipments especially for filter separator according to ASME code standard

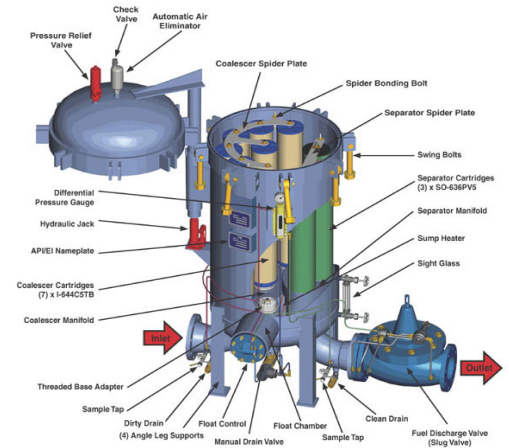
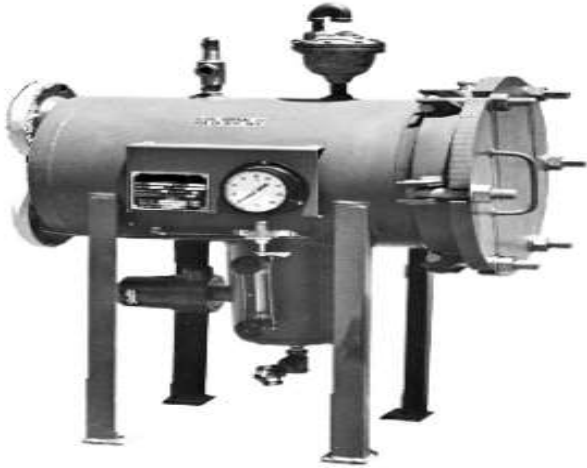

Horizontal fuel filter separators

vertical fuel filter separator



1- Flanged ball valve



199ASV

2- Anti siphon valve

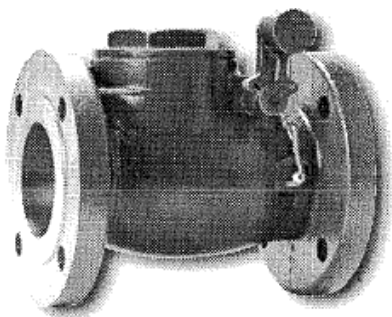

3- Emergency shut off valve

- ◆ **Meets worldwide technical specifications**
 Design BS5351, API 608, ASME/ANSI B16.34, face to face ANSI B16.10, fire testing BS6755 part 2, API 607 Rev. 4, API 6FA, performance testing BS6755 API 598 and ISO for all parameters of standardized valve automation.



Gravity Oil water separators & waste oil tank

AHC can provide underground Gravity oil water separators complete with all accessories

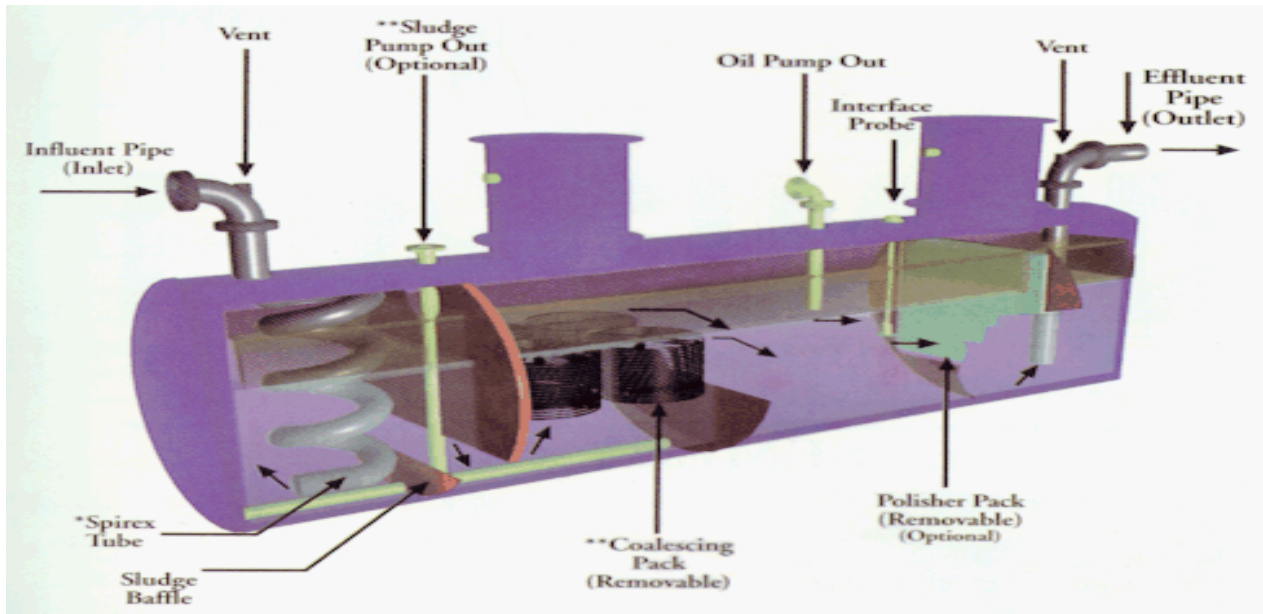

Gravity oil water separators

General Arrangement

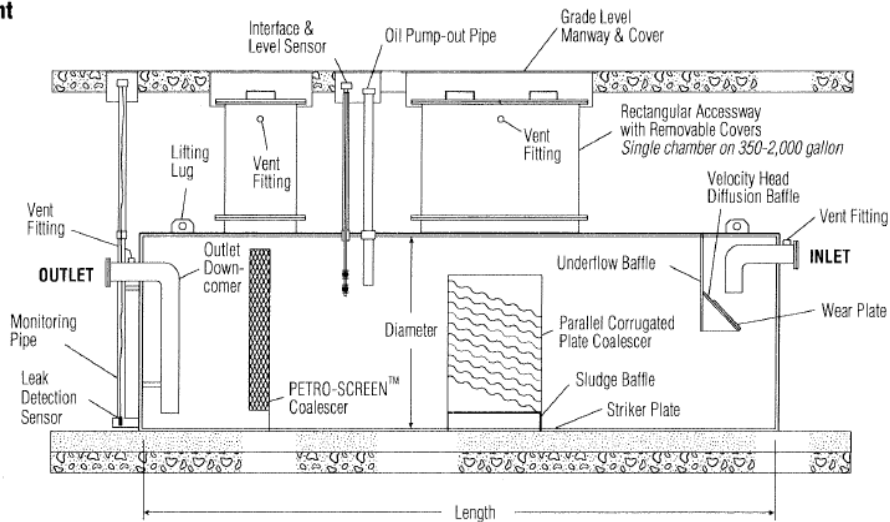

Complete with all accessories and leak detection system



Compressed Air System

AHC can provide Compressed Air System according to American Spec as factory-packaged assembly, complete with motor controls, switches, wiring, accessories, and motor controllers



Reciprocating compressor



Rotary air compressor

AHC can provide also all accessories of compressed Air system (Air Dryer, Pressure Regulators, Air Filters and Lubricators)



Air Dryers



Pressure regulators